

# Supplement to Driver's Manual for AVIA line D100 / D110 / D120 4x4

applicable to Driver's Manual - Edition 6 Series AVIA / English / 8 / 2009  
Information in this appendix is superior and alters data in Driver's Manual

## DESCRIPTION

### Controllers

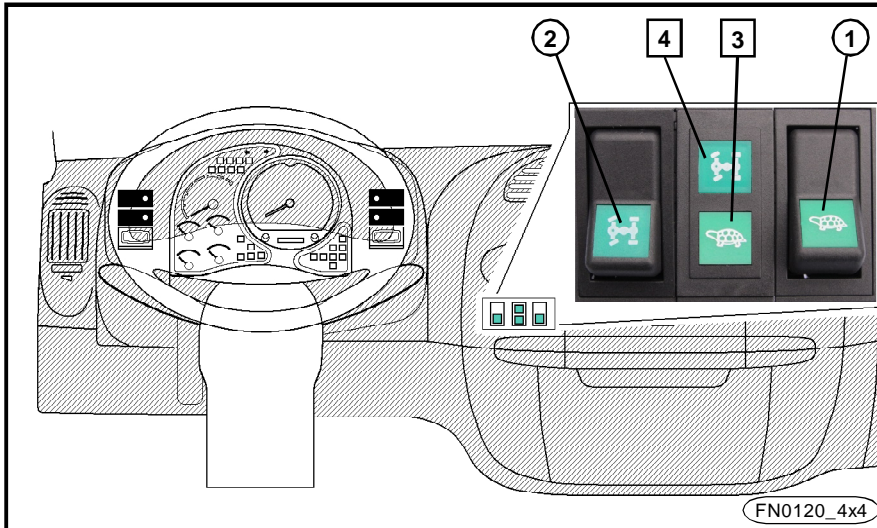

#### Front Drive (Switch Pos. 1)

- Engages front axle drive and at the same time reduced gearshift drive.
- Switching "ON" and "OFF" only when the vehicle is at rest (no movement) and at idle speed.
- Engagement is indicated by a control light Pos. 3.
- Use only for the time necessary to overcome difficult driving conditions.

#### Activating the front axle differential lock (Switch Pos. 2)

- Switching "ON" and "OFF" only when the vehicle is at rest (no movement) and at idle speed.
- Front axle differential is locked as long as the switch button (activator) is pressed.
- Use only for the time necessary to overcome difficult driving conditions.
- Engagement is indicated by the control light Pos. 4.
- The maximum speed with differential lock engaged is limited to 20 kms/hr.
- After disengagement of the differential lock it can happen that will go on being engaged for some time. During this time it is necessary to respect the maximum speed of 20 kms/hr and to adjust your driving style to these circumstances.

#### Warning!

- Front axle drive and the differential lock can be engaged only with the air pressure exceeding 0,55 MPa – otherwise the engagement is not ensured.
- Front wheel drive is designed for use on unpaved roads only. On roads it can be used only for the time period necessary to overcome difficult driving conditions.
- Differential lock is not designed for continuous operation. It can be used for the time period necessary to overcome difficult driving conditions.
- The differential lock must not be engaged while the vehicle is moving or the wheels are slipping.
- The vehicle is not designed to operate in difficult off-road conditions.
- It is recommended to switch on/switch off the differential lock 1x every week.

**Dimension of the chassis with cab**

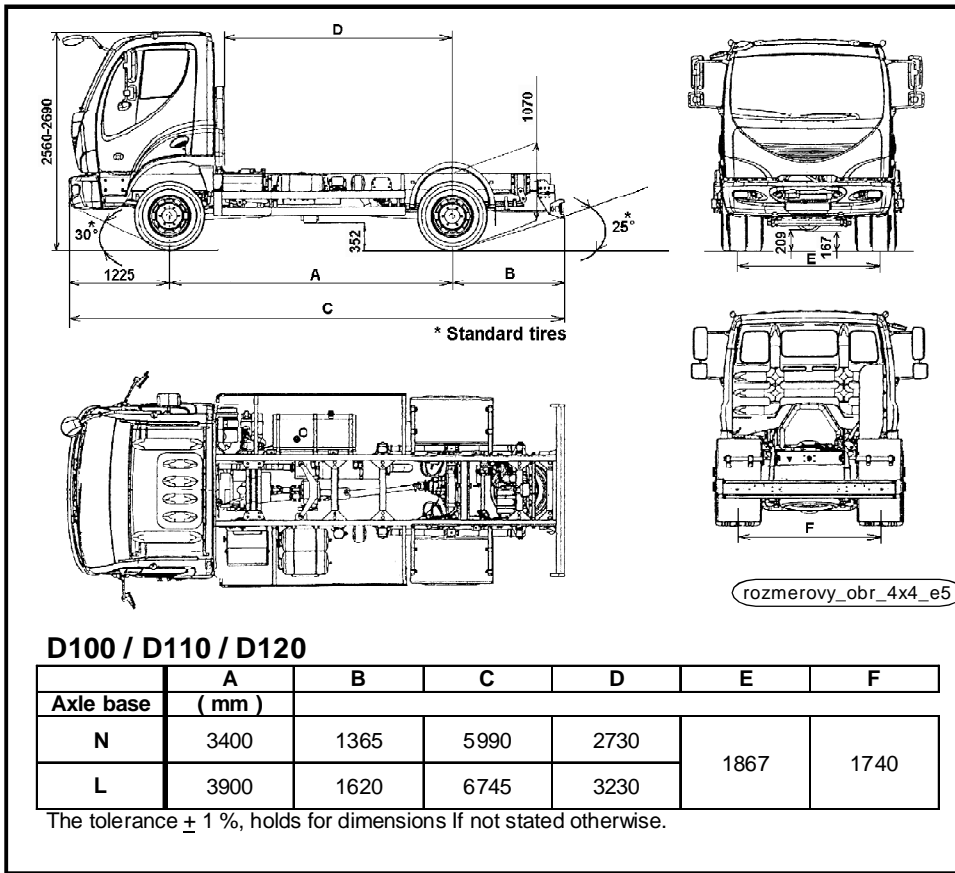

**Weights and Axle loads**

**D100 / D110 / D120**

	N	L
	( kg )	
Curb weight chassis + cabin	4132÷4182	4182÷4232
Carrying capacity of chassis + cabin (c/w crew)	5858÷5808 / 6858÷6808 / 7858÷7808	5808÷5758 / 6808÷6758 / 7808÷7758
Max.vehicle overall weight	9990 / 10990 / 11990	
The maximum allowable front axle load	3500 / 4000 / 4200	
The maximum allowable rear axle load	6600 / 7400 / 8200	

## Maintenance of the 4x4 drive components

### After first 1 000 kms

- Check-up of the oil level in the transfer box

### After first 3 000 kms

- **gear oil – transfer box – change (filling level – up to the lower edge of the filling (control) cap - about 4 litres)** + check-up of the gear box tightness + cleaning of the bleeding valves

Operational filling:

Transmission oil specification A P I	Recommended viscosity grade S A E
GL - 4	75 W - 90 80 W - 90 85 W - 90

Transfer box is supplied with a filling (control) and draining cap. Caps are marked by red colour, draining cap is furnished with a magnet.

### Every 5 000 kms

- Check-up of the oil level in the transfer box – the oil level must come up to the lower edge of the filling (control) cap

### Every 50 000 km / 1 year (whatever comes first)

- **gear oil – transfer box – change (the oil level must come up to the lower edge of the filling (control) cap – about 4 litres)** + check-up of the gear box tightness + cleaning of the bleeding valves

Operational filling:

as above mentioned

- **gear oil – transmission assembly of the front axle (up to the lower edge of the filling orifice - about 4l) – change** + tightness check-up (or 1 year, whatever comes first)

Operational filling:

Transmission oil specification A P I	Recommended viscosity grade S A E
GL - 5	85 W - 140

### Every three months

- Pins of U-joints of the connecting shafts (also between the gearboxes) – grease only if there are grease nipples at the joints
- Bearings of the front axle shafts – lubricate
- Axle shaft joints at pivot pins – lubricate
- steering pins (in total 4 greasing heads)
- cleaning of the bleeding valves

Filling:

plastic grease suitable for specific applications

Note: for all maintenance items, listed in the Service booklet for vehicles AVIA D100/D110/D120 4x4, the operation mode „heavy duty“ is to applied.